

Job _____

Item No _____

FireMax200™ Modular Water Heater

Model: **FM200N™ or FM200L™**



FEATURES AND BENEFITS

- Single point water, gas and electrical connections
- Factory-provided pressure and temperature relief valve
- Space saving design can be installed below dishtables
- All waterways constructed of stainless steel, copper and brass for corrosion protection and clean operation
- Simple, easy maintenance through front panel
- All stainless steel cabinet and frame
- Circulates to hot water storage tank

- All pumps, sensors and controls included
- Woven Ceramic Fiber Infrared Power Burner.
- Radial solid copper fin-tube heat exchanger for 360° heat transfer
- Burners activated by water flow and temperature.
- Advanced microprocessor controls
- Natural Gas or Liquid Propane 199,990 BTUH

ACCESSORIES AND OPTIONS

(available at extra cost)

- Factory Authorized StartUp-(highly recommended)
- Wall Mount Kit
- Water Hammer Arrester
- Water Pressure Gauge
- Water Pressure/Temperature Gauge
- Water pressure reducing valve (if water supply pressure exceeds 80psi)
- Low Pressure water pressure reducing valve (for dishwasher rinse)
- Auxiliary PowerVent required for extended flue lengths. Call factory
- EZ Install Kit
- Seismic Legs



FireMax200™ – Modular Water Heater

Model: FM200N™ or FM200L™

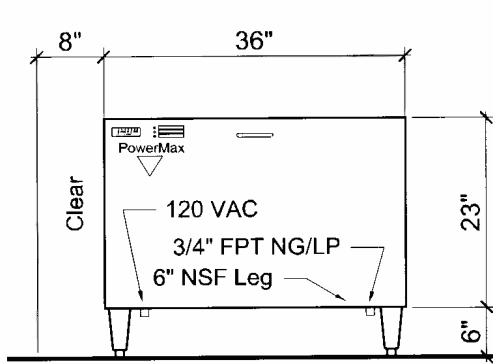

Front Elevation

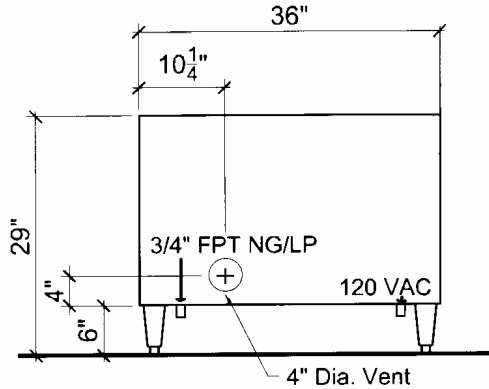

Rear Elevation

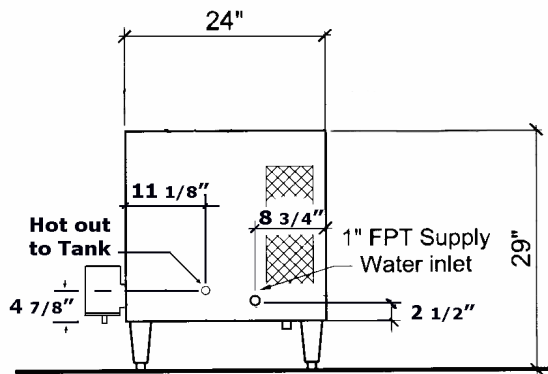

Left Elevation

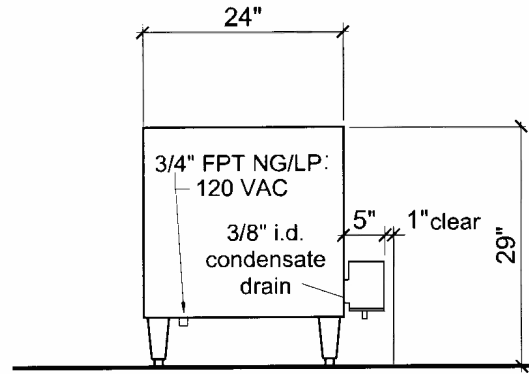

Right Elevation

Model Number	BtuH per burner Natural or Propane	Gas Connection	Water Supply	Electrical Connection	Gas Pressure Regulators	Shipping Weight
FM200™	199,990	3/4" NPT	1" NPT	120V 1ph 6.2 amps	One each Supplied	418 lbs

Natural Gas Pressure WC @ Inlet		LP Gas Pressure WC @ Inlet		Manifold Pressure WC		Water Pressure (Flow)		Re-circulating Loop	Clearance From Combustible Surface			Vent Per Local Code
Min	Max	Min	Max	Nat	LP	Min	Max	1"	Side	Top	Rear	Auxiliary Power Vent Required for extended flue lengths Call factory
7"	10.5"	10"	14"	3.5"	7.5"	40 psi	80 psi	To Storage Tank	6" L 1" R	1"	6"***	

	Temp Rise Output Temp	60°F	70°F	80°F	90°F	100°F	110°F
		110°F	120°F	130°F	140°F	150°F	160°F
FireMax200™/120gal	1 hour	475 gal	420 gal	390 gal	360 gal	336 gal	320 gal
BTU/Storage	2 hour	820 gal	740 gal	660 gal	600 gal	552 gal	520 gal
Firemax200™/240gal	1 hour	600 gal	540 gal	510 gal	480 gal	456 gal	440 gal
BTU/Storage	2 hour	940 gal	860 gal	780 gal	720 gal	672 gal	640 gal

**1" from back of exhaust vent

Contact factory if booster will be supplying dishwasher fill valves or tank heat.

Note: May be vented through the dishwasher canopy or pant-leg exhaust system per 1991 Uniform Mechanical Code Sec 916. & 917. Check with local authority



Printed in USA



R 6/05



FireMax200™ Modular Gas Water Heater specification

Water heater shall be a FireMax200™ gas water heater, Model FM200™ as manufactured by Vanguard Technology Inc., Eugene, OR 97402. Water Heater to be fired by a 199,990 Btu infrared power burner, using natural gas or liquid propane fuel, with a woven ceramic fabric burner. Burner to be ignited by means of a hot surface igniter and a redundant intermittent pilot light. Heat exchanger to be of heavy duty finned copper tubing and carry a 5 year limited warranty. Standard equipment to include gas pressure regulating valve, internal bronze-stainless re-circulation pump, integrated solid state power control, temperature and pressure relief valve and LED temperature display. Water Heater frame, body panels, and flue collar shall be of all stainless steel construction. Unit shall stand on 6 inch adjustable stainless or composite NSF approved legs. Stainless steel front panel to be removable for access to all components without disconnecting water heater from its installed location. Water Heater to be rated at 88% operating efficiency, minimum. Water heater shall be connected and circulated to one or more hot water storage tanks and controlled by temperature sensors in tank(s).